

# COMBINATION STACK WASHER/DRYER

MLE/MLG22PRTGW  
MLG22PRTKW

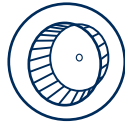

CARD READER READY & NON-VEND  
MLE/MLG22PRTGW/KW



## TURBOVENT® SYSTEM

- Enables installation in long or complicated venting environments
- Helps improve component life
- High airflow helps reduce drying times for a wide variety of loads



## DURACORE DRIVE SYSTEM

- Designed and tested to run 15,000 cycles\*
- Watertight, flexible triple-lip seal with garter spring keeps moisture away from the shaft, protecting the premium bearings
- Durable shaft sleeve is designed to eliminate shaft wear

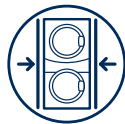

## SPACE-SAVING CONFIGURATION

- Full-capacity washer & dryer within the footprint of a single machine
- Console design lowers dryer height for easier loading and unloading



## BUILT TO LAST

- Premium bearings — oversized premium NSK bearings are sealed for added protection of the drive system
- Robust hinges — heavy-duty, die-cast door hinges open 180° and are built to withstand the rigors of commercial laundry
- Blower guard — protects components to reduce service calls
- Durable soap dispenser is fully flushed with water during every wash cycle, helping minimize maintenance



**AMERICA**  
AN AMERICAN COMPANY FOR OVER 100 YEARS

See [maytagcommerciallaundry.com](http://maytagcommerciallaundry.com) for warranty details.

 End user benefits

\*Based on 11-lb load, 34 min. timed cycle, Heavy Soil.

VISIT [MAYTAGCOMMERCIALLAUNDRY.COM](http://MAYTAGCOMMERCIALLAUNDRY.COM) FOR MORE INFORMATION.

®/™ © 2023 Maytag. All rights reserved.  
MY220181 05/23

# COMBINATION STACK WASHER/DRYER

MLE/MLG22PRTGW  
MLG22PRTKW



## SIDE VIEW

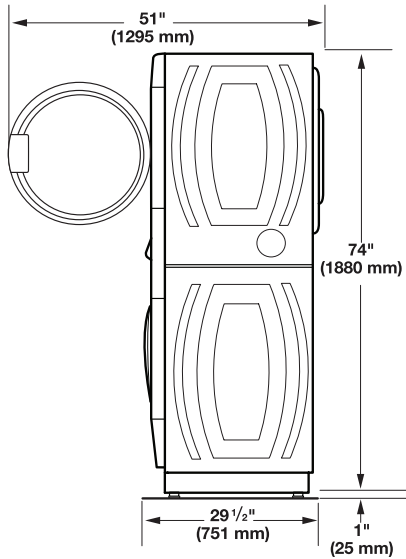

## BACK VIEW

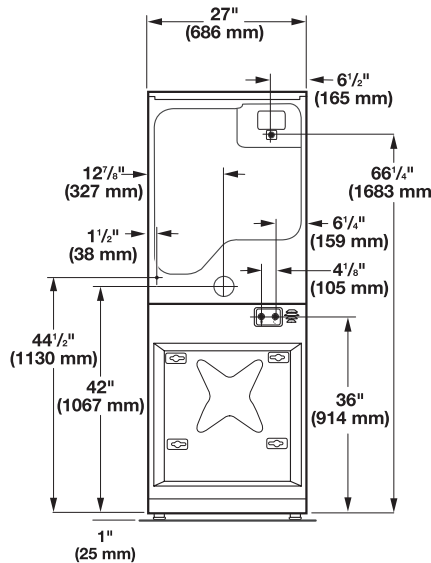

### MAXIMUM EXHAUST DUCT LENGTH PER NUMBER OF TURNS

Number Of 90° Turns	Rigid Metal Vent	
	Box Hood and Louvered Style	Angled Hood Style
0	39.6 m (130 ft.)	39.3 m (129 ft.)
1	38.1 m (125 ft.)	36.3 m (119 ft.)
2	35.1 m (115 ft.)	33.2 m (109 ft.)
3	32.3 m (106 ft.)	30.5 m (100 ft.)
4	29.9 m (98 ft.)	28.0 m (92 ft.)

MODELS	MLE22PRTGW	MLG22PRTGW	MLG22PRTKW
<b>PAYMENT CONFIGURATION</b>	Card Ready & Non-Vend		
<b>FUEL TYPE</b>	Electric	Gas	
<b>CAPACITY</b>			
Washer Capacity — cu. ft. (liters)	3.1 (88)	3.1 (88)	3.1 (88)
Dryer Capacity — cu. ft. (liters)	6.7 (190)	6.7 (190)	6.7 (190)
IEC Capacity — lb. (kg)	23.2 (10.5)	23.2 (10.5)	23.2 (10.5)
<b>DIMENSIONS</b>			
Width — in. (mm)	27 (686)	27 (686)	27 (686)
Depth — in. (mm)	29.5 (751)	29.5 (751)	29.5 (751)
Height — in. (mm)	74 (1,880)	74 (1,880)	74 (1,880)
Door Opening — in. (mm)	14.25 (362)	14.25 (362)	14.25 (362)
Exhaust Duct Diameter — in. (mm)	4 (102)*	4 (102)*	4 (102)*
<b>CRATED DIMENSIONS</b>			
Crated Width — in. (mm)	29.25 (743)	29.25 (743)	29.25 (743)
Crated Depth — in. (mm)	34 (864)	34 (864)	34 (864)
Crated Height — in. (mm)	75.75 (1,924)	75.75 (1,924)	75.75 (1,924)
<b>APPROXIMATE WEIGHT</b>			
Uncrated — lb. (kg)	372 (169)	378 (171)	378 (171)
Crated — lb. (kg)	372 (169)	378 (171)	378 (171)
<b>ELECTRICAL REQUIREMENTS</b>			
Voltage	240V	240V	240V
Frequency	50Hz	50Hz	60Hz
Breaker/Fuse — Amps	30	15	15
Airflow — CFM (CMM)	215 (6.10)	230 (6.5)	230 (6.5)
Electric Heating Element (watts)	4,600	N/A	N/A
Gas Rating — BTU/hr (kcal/hr)	N/A	20,000 (5,040)	20,000 (5,040)
Gas Inlet Size — in.	N/A	3/8 N.P.T.	3/8 N.P.T.
Motor Size — HP (kW)	1/3 (.25)	1/3 (.25)	1/3 (.25)



\*Use 4" (100 mm) diameter rigid aluminum or galvanized steel duct. Never use plastic, non-metal or combustible duct. See specific instructions for proper installation. Because of continuous product improvement, Maytag reserves the right to change specifications without notice. Export model ships without coin-drop mechanism.