



Maximum Performance



UDR190

FEATURES AND BENEFITS

- Standard galvanized drum with large diameter
- Easy-to-use microprocessor (ECT)
- Combination of radial and axial airflow
 - maximal heat transfer
 - low energy consumption
 - short drying time
- Large door opening for easy loading and unloading

OPTIONS

- Reversing drum
- Stainless steel drum
- Double door glass and insulation
- Full control programmer
- Residual moisture control:
 - Safe drying of delicate linen
 - Humidity detection in %
 - Ideal for fire departments
 - Available on Easy and Full Control
- Stainless steel front
- Wireless communication with cloud-based systems (WiFi kit- to order through Accessories)

INDUSTRIAL TUMBLE DRYER

TYPE		UDR190	
CAPACITY			
Capacity 1:18	kg/lbs	9 / 20	
Capacity 1:22	kg/lbs	8 / 18	
Drum volume	l	190	
Drum diameter	Ø mm	760	
DRYING PERFORMANCE			
Airflow	m ³ /h	350	
Drying average	l/min	0,150	
MOTOR			
Fan	kW	0,37	
Drive	kW	0,18	
GAS HEATING			
Energy	kW	12,5	
Energy	kBTU/h	42,7	
Electrical connection		3x380-415V 50/60Hz, 3x220-240V 50Hz, 3x208-240V 60Hz, 3x440V 60Hz	
Gas connection	inch	1/2"	
ELECTRICAL HEATING			
Energy	kW	6/9/12	
Electrical connection		3x380-415V 50/60Hz, 3x220-240V 50Hz, 3x208-240V 60Hz, 3x440V 60Hz, 3x480V 60Hz	
CONNECTION			
Exhaust	mm	Ø150	
PROGRAMMER			
Easy Control with antivandal (ECT)		Standard	
Full Control		Available	
DIMENSIONS			
H×W×D	mm	1465 x 795 x 815	
Net weight	kg	170	
TRANSPORT DATA			
Packed H×W×D	mm	1570 x 880 x 885	
Gross weight	kg	180	

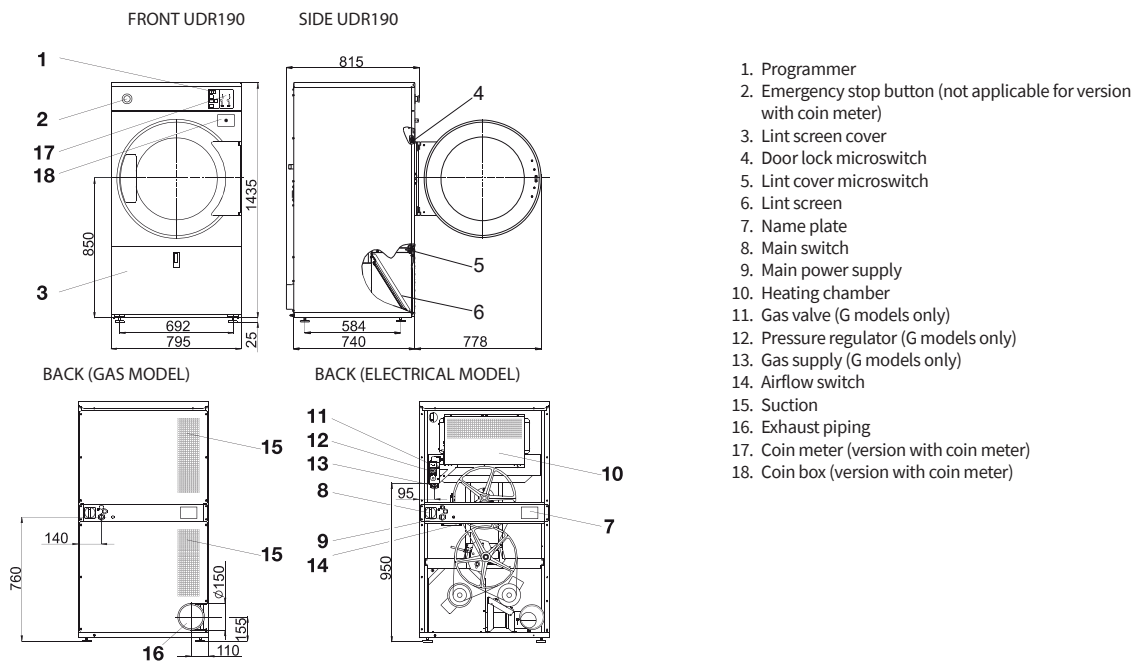

TO LEARN MORE, OR TO FIND A DISTRIBUTOR IN YOUR AREA, VISIT UNIMAC.COM
ALLIANCE LAUNDRY SYSTEMS - SHEPARD ST, RIPON WI 54971 - +1 800 587 5458

Consult your UniMac® distributor for details. For the most accurate information, the installation guide should be used for all design and construction purposes. Due to continuous product improvements, design and specifications subject to change without notice. The quality management systems at Alliance Laundry Systems' Ripon facility has been registered to ISO 9001:2008.

©2023 Alliance Laundry Systems LLC.

UniMac® by Alliance Laundry Systems